

HANDRAILS AND BRACKETS

Julius Blum & Co., Inc. stocks a large variety of handrail mouldings and brackets for horizontal and vertical mounting in elevator cabs. Matching elbows and end caps are available for most sections. Handrail sections are supplied with a smooth mill finish suitable for architectural finishes.

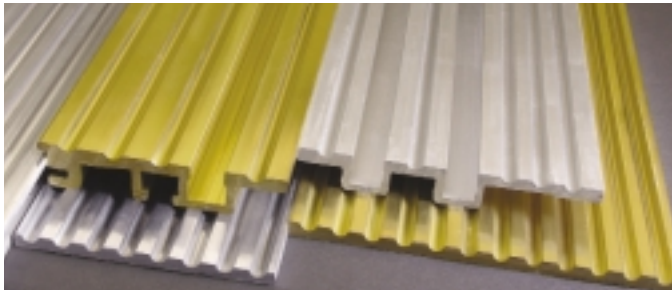

SADDLES

Elevator and Door Saddles are available in aluminum, bronze, nickel-silver, stainless steel and steel. Flat fluted sections may be combined with single or double speed saddles to extend width. Saddle alloy matches handrail alloy.



MOULDINGS

A variety of other architectural mouldings are available. These mouldings provide for alternative methods of glass framing or door edging. Stair nosings in bronze and aluminum are also available from stock. Mouldings are frequently combined in restoration work.

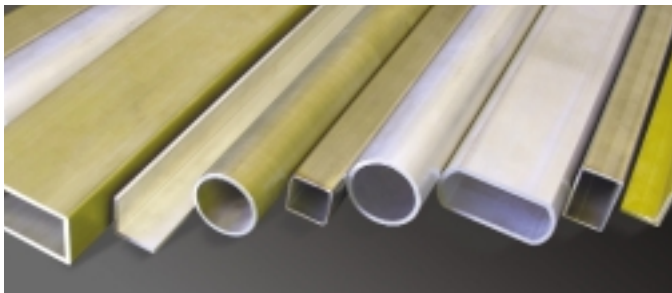

TUBING, BARS AND SHAPES

A large selection of tubing, bars, and shapes in aluminum, bronze, steel, nickel-silver and stainless steel are available from stock. Shapes are extruded to high tolerances and have the sharp corners required for architectural work. Angles and tees are used frequently in dropped ceilings as well as other areas of elevator cabs.

This section contains details on the Julius Blum & Co. components which are of particular use in the assembly of elevator cabs. Included are **Elevator Door Saddles** and **Flat Fluted Sections** in aluminum, bronze, nickel-silver, stainless steel and handrail mouldings and brackets which are suitable for vertical mounting.

● **Aluminum** components are of alloy 6063—extrusions are T52 temper while machined brackets are T6 temper. When properly fabricated, they are suitable for anodizing, including most of the hard coat anodic processes. Black anodizing may result in inconsistent matches—consult your anodizer before specifying.

● **Bronze** components are of extruded architectural bronze alloy, C38500.

● **Nickel-Silver** saddles, fluted sections and handrail are extruded from copper-nickel-zinc alloy, C79800.

● **Stainless Steel** components are made of Type 302/304 (18-8) stainless steel.

All brackets are satin finished.

● **Acrylic/Wood** handrail mouldings—in oak, walnut and ash—are impregnated with acrylic plastic according to the Permagrain Radiation Process. This provides a hard surface and permanent finish which has twice the resistance to indentation and several times the resistance to abrasion as the same hardwood finished conventionally. It is laminated from several strips so as to obtain greater strength and continuous uniform lengths. For more information, see pages 62-63.

Refer to pages 104 to 122 for our full range of tubing, bars and shapes in aluminum, bronze, nickel-silver, steel and stainless steel.

ELEVATOR CAB COMPONENTS

● **Aluminum** components are of alloy 6063-T52. When properly fabricated, they are suitable for anodizing—including most of the hard-coat anodic processes. Black anodizing may result in inconsistent matches. Consult your anodizer before specifying.

● **Bronze** components are of extruded architectural bronze alloy, C38500.

● **Nickel-Silver** handrails, saddles, and sections are extruded from nickel-silver alloy, C79800.

● **Stainless Steel** components are made of Type 302/304 (18-8) stainless steel.

FLAT FLUTED SECTIONS

20' lengths, except as noted
For assembled saddles

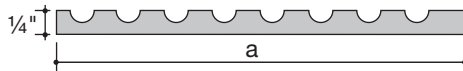

		a	lb/ft
6980	● Aluminum	1"	.234
6970	● Aluminum	1½"	.361
6971	● Aluminum	2"	.482
6973	● Aluminum	3"	.723
6975	● Aluminum	4"	.964
4566	● Bronze	1"	.720
4558	● Bronze	1½"	1.150
4557	● Bronze	2"	1.480
4556	● Bronze	2½"	1.840
4555	● Bronze	3"	2.230
4554	● Bronze	3½"	2.550
4553	● Bronze	4"	2.890
4553Q	● Bronze	4¼"	3.260
4552	● Bronze	4½"	3.290
4551	● Bronze	5"	3.670
4550*	● Bronze	5½"	4.050
4559*	● Bronze	6⅛"	4.550
5558***	● Nickel-Silver	1½"	1.150
5553***	● Nickel-Silver	4"	3.040
6573**	● Stainless	2¾"	1.780
6575**	● Stainless	4"	3.050

* 16' lengths, ** 8' lengths, *** 10' lengths

EXTENSION

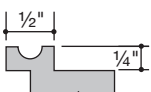

		lb/ft	Lengths
6967	● Aluminum	.314	20'
4567	● Bronze	1.040	20'
5567	● Nickel-Silver	.950	20'

ELEVATOR DOOR SADDLES

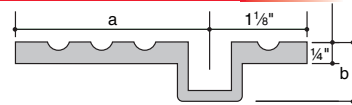

		a	b	lb/ft	Lengths
6963	● Aluminum	2¼"	1⅛"	.85	20'
6969	● Aluminum	2⅞"	1⅛"	1.08	20'
4563	● Bronze	2¼"	1⅛"	2.96	6', 8', 16'
4569	● Bronze	2⅞"	1⅛"	3.76	6', 8', 10'
5563	● Nickel-Silver	2¼"	¾"	3.58	6', 8', 10'
5569	● Nickel-Silver	2⅞"	1⅛"	4.16	6', 8', 10'

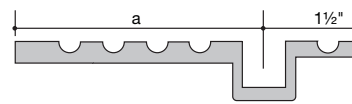

		a	b	lb/ft	Lengths
6964	● Aluminum	2¼"	1⅛"	1.25	20'
6979	● Aluminum	2⅞"	1⅛"	1.44	20'
4564	● Bronze	2¼"	1⅛"	4.25	6', 8', 10', 16'
4579	● Bronze	2⅞"	1⅛"	5.09	6', 8', 10', 16'
5564	● Nickel-Silver	2¼"	¾"	4.63	6', 8', 10'
5579	● Nickel-Silver	2⅞"	1⅛"	6.35	6', 8', 10'

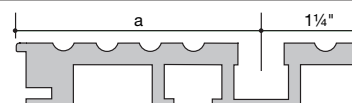

		a	b	lb/ft	Lengths
6989	● Aluminum	2¾"	1⅜"	1.54	20'
4589	● Bronze	2¾"	1⅜"	4.79	8', 10'
5589	● Nickel-Silver	2¾"	1⅜"	5.05	8', 10'

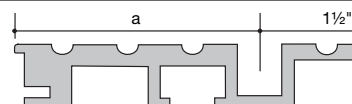

		a	b	lb/ft	Lengths
6999	● Aluminum	2¾"	1⅜"	2.10	20'
4599	● Bronze	2¾"	1⅜"	6.55	8', 10'
5599	● Nickel-Silver	2¾"	1⅜"	7.00	8', 10'

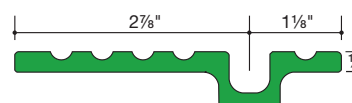

6569	● Stainless	3.71 lb/ft	8' lengths
------	-------------	------------	------------

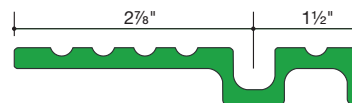

6579	● Stainless	5.530-* lb/ft	8' lengths
------	-------------	---------------	------------



6589	● Stainless	5.35 lb/ft	8' lengths
------	-------------	------------	------------



6599	● Stainless	7.52 lb/ft	8' lengths
------	-------------	------------	------------

DOOR SADDLES

20' lengths, except as noted

FLUTED

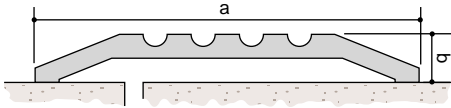

		lb/ft	a	b	Lengths
6924	● Aluminum	.72	3"	1/2"	16'-3"
6923	● Aluminum	1.05	4"	1/2"	20'
6926	● Aluminum	.83	4"	1/2"	16'-3"
6922	● Aluminum	1.27	5"	1/2"	20'
6920	● Aluminum	1.53	6"	5/8"	20'
6921	● Aluminum	1.23	6"	1/2"	16'-3"
6925	● Aluminum	1.76	7"	1/2"	20'
4524	● Bronze	2.11	3"	3/8"	20'
4523	● Bronze	3.05	4"	1/2"	20'
4522	● Bronze	3.79	5"	1/2"	20'
4520	● Bronze	4.64	6"	5/8"	20'
4519	● Bronze	5.14	7"	1/2"	12'

SMOOTH

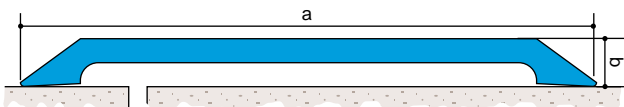

		lb/ft	a	b	Lengths
6910	● Aluminum	.365	2 1/2"	1/4"	20'
6914	● Aluminum	.476	3"	1/4"	16'-3"

BUTT SADDLE

21'-1" lengths

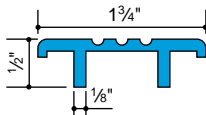

6915	● Aluminum	.398 lb/ft
------	------------	------------

CARPET SADDLE

21'-1" lengths

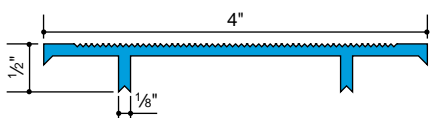

6916	● Aluminum	.653 lb/ft
------	------------	------------

WEATHER STRIP DOOR SADDLES

20' lengths, except as noted

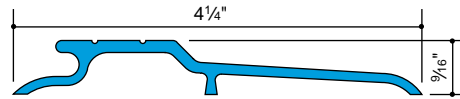

6991	● Aluminum	16'-3" lengths	.689 lb/ft
------	------------	----------------	------------

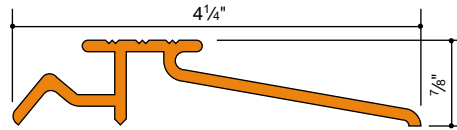

4596	● Bronze	2.21 lb/ft
------	----------	------------

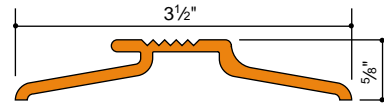

4590	● Bronze	1.92 lb/ft
------	----------	------------

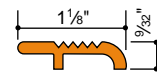

4598	● Bronze	.62 lb/ft
------	----------	-----------

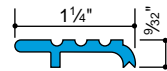

6998	● Aluminum	16'-3" lengths	.18 lb/ft
------	------------	----------------	-----------

BATHROOM DOOR SADDLES

20' lengths

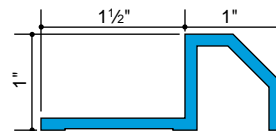

6948	● Aluminum	.576 lb/ft
------	------------	------------

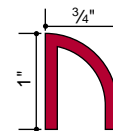

4487	● Steel	.93 lb/ft
------	---------	-----------

Typical Details

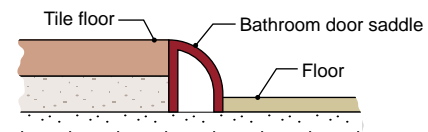
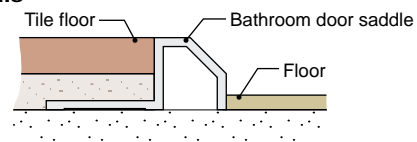

● ● ● DOOR ELEVATOR SADDLES AND HANDRAIL MOULDINGS

DOOR SADDLE SECTION

21'-4" lengths

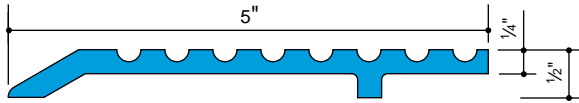

6913 ● Aluminum 1.48 lb/ft

Typical Door Saddle Details

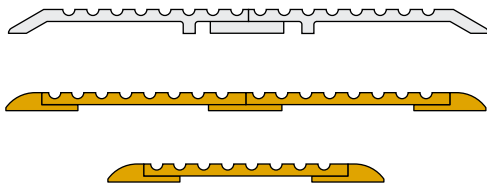

Cutouts for floor hinges can be made easily before assembly.

Wider saddles can be constructed by adding a flat fluted section in the center. The pattern of all fluted sections is identical, and joints with saddle sections will not be apparent.

Saddles of extreme width can be constructed by using bevel end sections and two or more flat fluted sections with a plate underneath.

BEVEL END SECTIONS

20' lengths



4526 ● Bronze 1.35 lb/ft 4528 ● Bronze 1.09 lb/ft

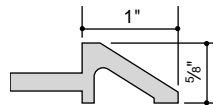

6927 ● Aluminum .45 lb/ft
4527 ● Bronze 1.48 lb/ft

NOSINGS

20' lengths

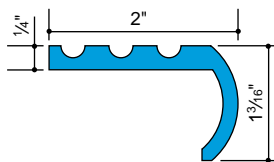

6961 ● Aluminum .722 lb/ft

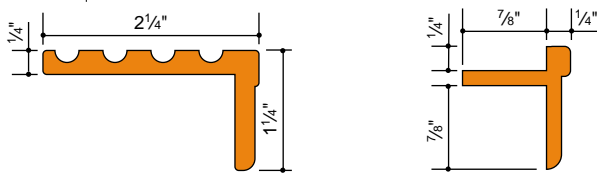

4560 ● Bronze 2.45 lb/ft 4565 ● Bronze 1.31 lb/ft

ROOF DOOR SADDLE

20' lengths

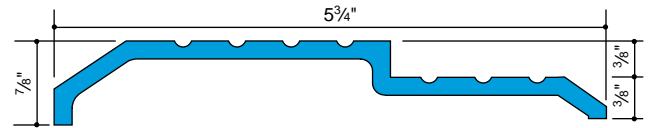

6997 ● Aluminum 1.45 lb/ft

ACRYLIC / WOOD HANDRAIL MOULDINGS

20' lengths

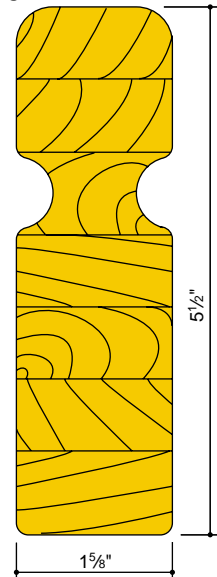

8591 ● Oak Acrylic/Wood

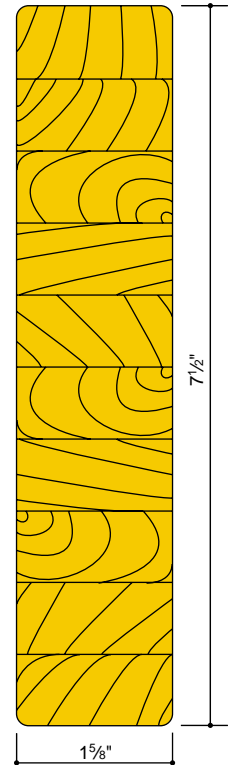

8561 ● Oak Acrylic/Wood
8562 ● Walnut Acrylic/Wood

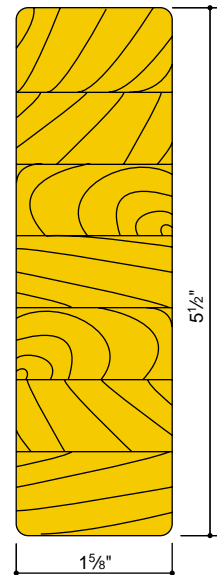

8521 ● Oak Acrylic/Wood
8522 ● Walnut Acrylic/Wood
8523 ● Ash Acrylic/Wood



Approximate color and grain configurations
Ash color may be substituted for maple or birch.



Julius Blum & Co. Inc.

HANDRAIL MOULDINGS

- ALUMINUM
- NICKEL-SILVER
- BRONZE
- STAINLESS

BRONZE

C38500, Mill Finish
20' lengths

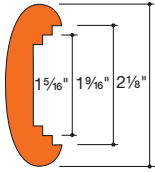

4535 ● 3.16 lb/ft
Fittings: end cap

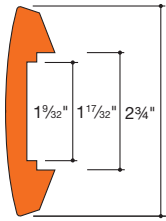

4574 ● 3.71 lb/ft
Fittings: end cap

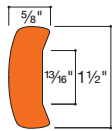

4503 ● 2.75 lb/ft
Fittings: C-N

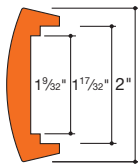

4575 ● 2.64 lb/ft
Fittings: end cap

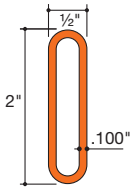

6488* ● 1.56 lb/ft
Fittings: end cap

*16 lengths

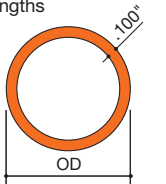

6489 ● 1 1/2" 1.75
1.90" 2.07
Fittings: end cap, elbow

NICKEL-SILVER

C79800, 20' lengths

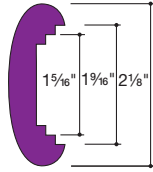

5235 ● 3.16 lb/ft
Fittings: end cap

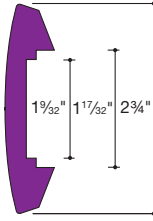

5274 ● 3.71 lb/ft
Fittings: end cap

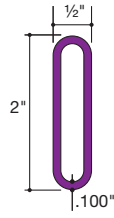

5288 ● 1.56 lb/ft
Fittings: end cap

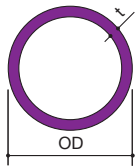

	OD	t	lb/ft
5289 ●	1 1/2"	.100"	1.75
	1.90"	.109"	2.25

Fittings: end cap

STAINLESS

Type 302/304 (18-8), 20' lengths
Mill Finish

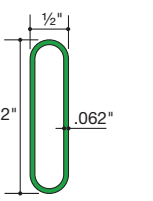

4488 ● .944 lb/ft
Fittings: end cap

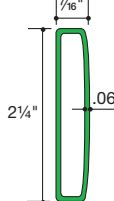

6512 ● 1.00 lb/ft
Fittings: end cap

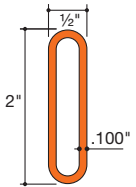

6488* ● 1.56 lb/ft
Fittings: end cap

*16 lengths

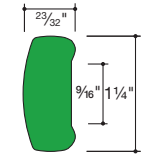

6503* ● 2.54 lb/ft
Fittings: end cap

*16 lengths

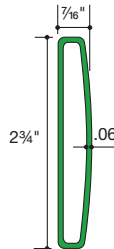

6511 ● 1.25 lb/ft
Fittings: end cap

Satin Finish

Pipe size	OD	t	lb/ft
3/4"	1.06	.113"	1.20
1"	1.32	.120"	1.46
1 1/4"	1.66	.062"	1.11
1 1/4"	1.66	.148"	2.15
1 1/2"	1.90	.062"	1.27
1 1/2"	1.90	.148"	2.55

Fittings: end cap, elbow

ALUMINUM

6063-T52, 20' lengths, Mill Finish

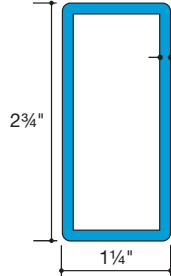

6434 ● 1.123 lb/ft
Fittings: end cap

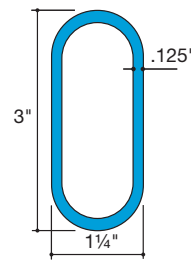

6437 ● 1.057 lb/ft
Fittings: end cap

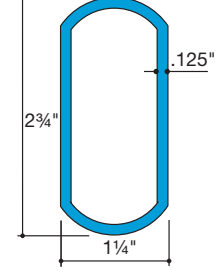

6435 ● 1.075 lb/ft
Fittings: end cap
* 6063-T6

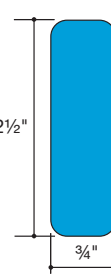

6939 ● 2.214 lb/ft

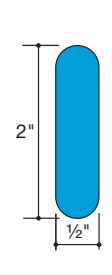

6988 ● 1.138 lb/ft

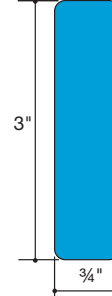

6986 ● 2.684 lb/ft

ALUMINUM

6063-T52, 20' lengths

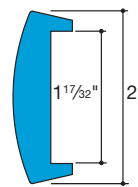

6985 ● .980 lb/ft
Fittings: end cap

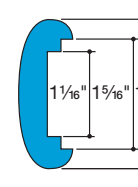

6933 ● .770 lb/ft
Fittings: end cap

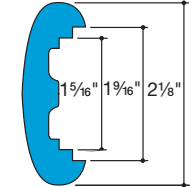

6935 ● .977 lb/ft
Fittings: end cap

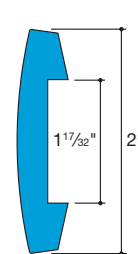

6984 ● 1.301 lb/ft
Fittings: end cap

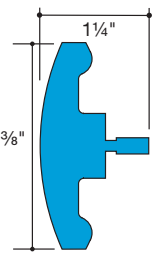

6402 ● 1.510 lb/ft
Fittings: end cap

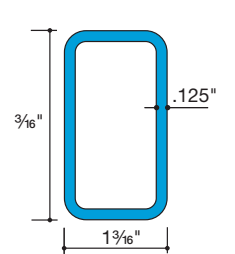

6436 ● .888 lb/ft
Fittings: end cap

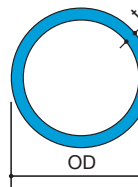

Pipe size	OD	Sch.	t	lb/ft
1 1/4"	1.66"	10	.109"	.625
1 1/4"	1.66"	40	.140"	.785
1 1/2"	1.90"	10	.109"	.721
1 1/2"	1.90"	40	.145"	.940

Fittings: end cap, elbow

● ● ● ● MOUNTING BRACKETS

TWO-PIECE MOUNTING BRACKETS

Satin Finish

168* ● Aluminum
 898 ● Bronze
 298 ● Stainless

166* ● Aluminum
 896 ● Bronze
 196 ● Nickel-Silver
 296 ● Stainless

For wide wood handrails

160* ● Aluminum
 890 ● Bronze
 290 ● Stainless

169* ● Aluminum
 899 ● Bronze
 299 ● Stainless

* Also available in clear anodized AA-M32-C22-A31 (204R1)

THREADED BUSHING BRACKETS

Satin Finish

163 ● Aluminum
 63 ● Stainless

164 ● Aluminum
 64 ● Stainless

VERTICAL MOUNTING BRACKET

Satin Finish

151 ● Aluminum

ADAPTERS

Satin Finish

7164* ● Aluminum .830" Use With 1.660" OD
 7264* ● Aluminum .950" 1.900" OD
 8864 ● Bronze .950" 1.900" OD
 8964 ● Bronze .750" 1.500" OD
 5264 ● Nickel-Silver .750" 1.500" OD
 5364 ● Nickel-Silver .950" 1.900" OD
 9364 ● Stainless .950" 1.900" OD

* Also available in clear anodized AA-M32-C22-A31 (204R1)



JuliusBlum&Co.Inc.



GLASS FRAMING SECTIONS

Full Scale

GLAZING MEMBERS

20' lengths, except as noted

Aluminum and bronze glass stop/snap-in and flexible PVC glazing channel serve to mount panels of 1/4" glass, plastic, wire mesh or other material.

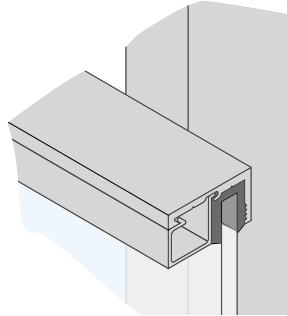

GLASS STOP

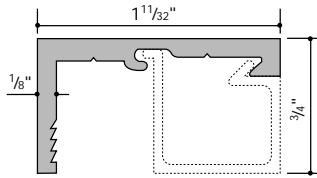

8106	Aluminum Mill finish	.276 lb/ft
8206	Aluminum Clear anodized, AA-M10-C22-A31 (204R1)	.276 lb/ft
4506*	Bronze	.950 lb/ft

* 16' lengths

SNAP-IN

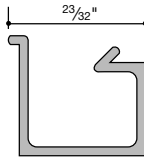

8107	Aluminum Mill finish	.138 lb/ft
8207	Aluminum Clear anodized, AA-M10-C22-A31 (204R1)	.138 lb/ft
4507*	Bronze	.510 lb/ft

* 16' lengths

FLEXIBLE PVC CHANNEL

50' coils

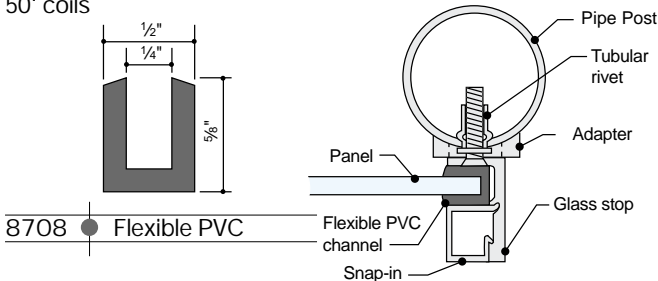

8708	Flexible PVC	
------	--------------	--

COVE MOULDINGS AND GLASS STOPS

20' lengths

6952	Aluminum	.166 lb/ft
6102	Bronze	.500 lb/ft

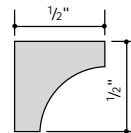

6955	Aluminum	.260 lb/ft
6105	Bronze	.670 lb/ft

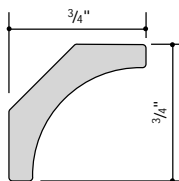

GLASS FRAMING SECTIONS

20' lengths

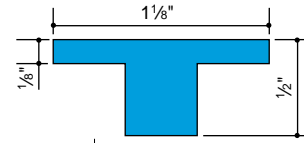

6958	Aluminum	.338 lb/ft
------	----------	------------

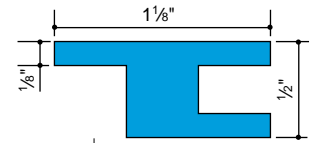

6959	Aluminum	.394 lb/ft
------	----------	------------

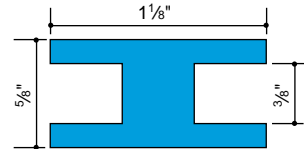

6960	Aluminum	.507 lb/ft
------	----------	------------

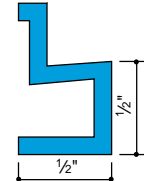

6953*	Aluminum	.183 lb/ft
-------	----------	------------

* 16' lengths

Framing Detail

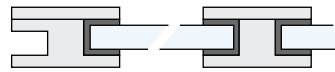

Sections 6958 and 6959 with flat bars

VARIOUS MOULDINGS

20' lengths

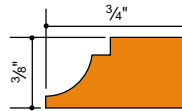

6473	Bronze	.76 lb/ft
------	--------	-----------

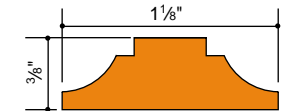

6474	Bronze	1.01 lb/ft
------	--------	------------

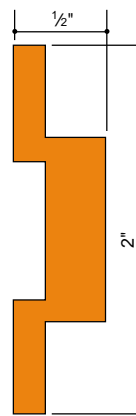

6140	Bronze	1.97 lb/ft
------	--------	------------

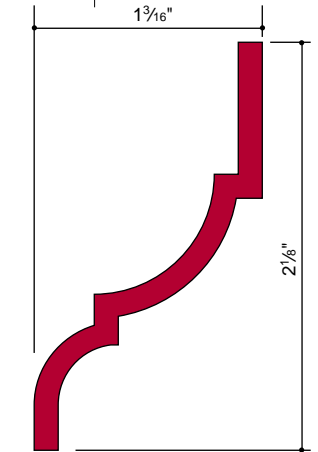

4302	Steel	1.15 lb/ft
------	-------	------------

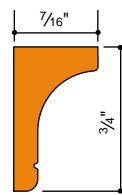

6121	Bronze	.60 lb/ft
------	--------	-----------

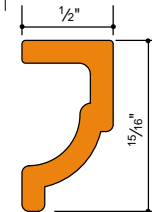

6130	Bronze	.70 lb/ft
------	--------	-----------

● ALUMINUM

● BRONZE

● ● DOOR EDGINGS, ADAPTER BARS AND WINDOW SILLS

DOOR EDGINGS

16' lengths, except as noted. Full Scale.

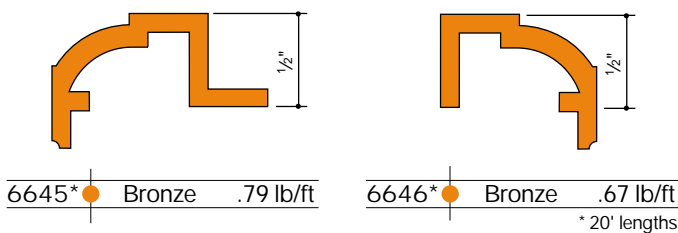
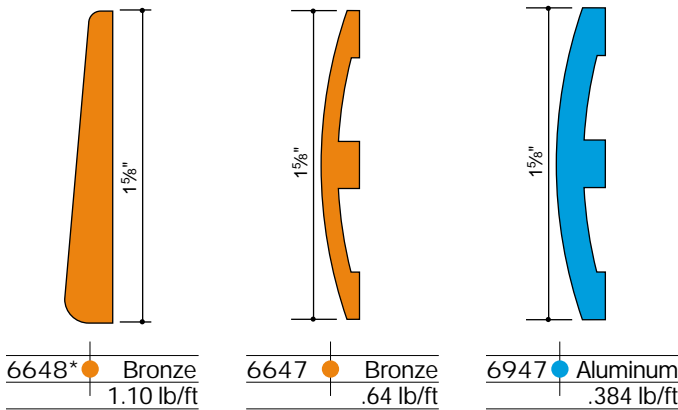
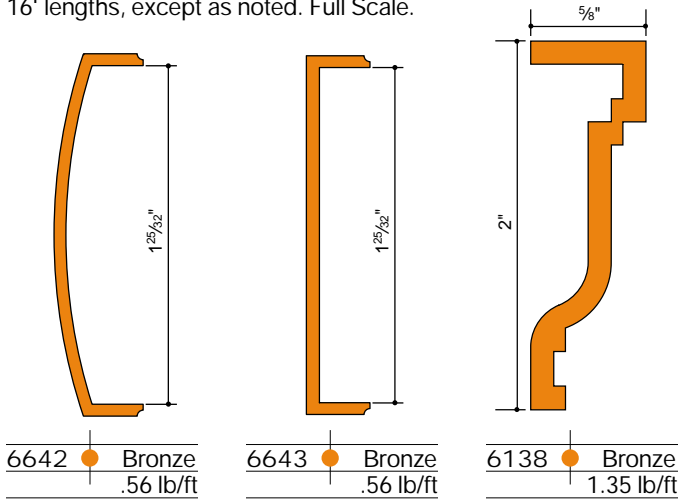

Typical Details

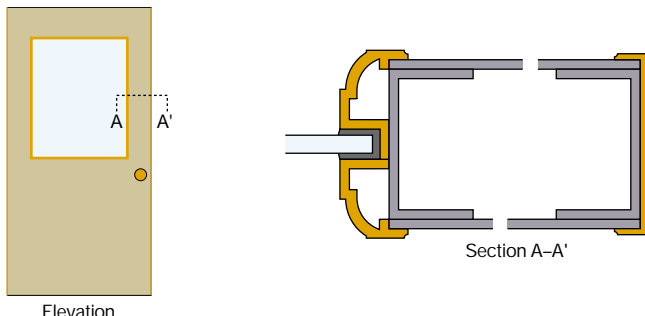

Detail at A-A' with 6643, 6645 and 6646

ADAPTER

16' lengths

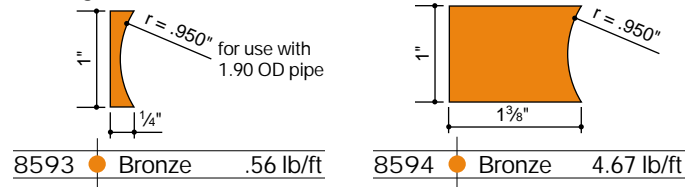

PANEL CLIPS

Aluminum, 5' lengths

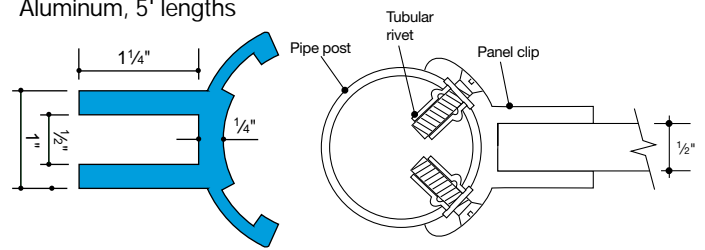

See page 19 for 1" clips.

	Pipe
7460-5 ● Aluminum	1 1/4"
7560-5 ● Aluminum	1 1/2"

WINDOW SILLS, TYPE AA

21' lengths, Aluminum, 6063-T52

SA-100 anchor clip spacing to be not more than 3'-0"

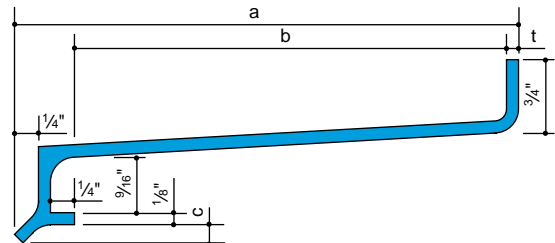

ALCOA		lb/ft	a	b	t	c
54684 ● Aluminum		.767	3 1/2"	2 1/4"	1/8"	3/16"
54685 ● Aluminum		.842	4"	3 1/4"	1/8"	3/16"
54686 ● Aluminum		.919	4 1/2"	3 3/4"	1/8"	3/16"
54687 ● Aluminum		.994	5"	4 1/4"	1/8"	3/16"
54688 ● Aluminum		1.067	5 1/2"	4 3/4"	1/8"	3/16"
54689 ● Aluminum		1.141	6"	5 1/4"	1/8"	3/16"
54690 ● Aluminum		1.529	6 9/16"	5 3/4"	5/32"	3/16"
54693 ● Aluminum		2.414	9 1/8"	8 1/4"	3/16"	1/4"

ANCHOR CLIP FOR TYPE AA WINDOW SILLS

ALCOA SA-100 ● Aluminum

